

Posi ZORB

OIL/WATER SEPARATOR

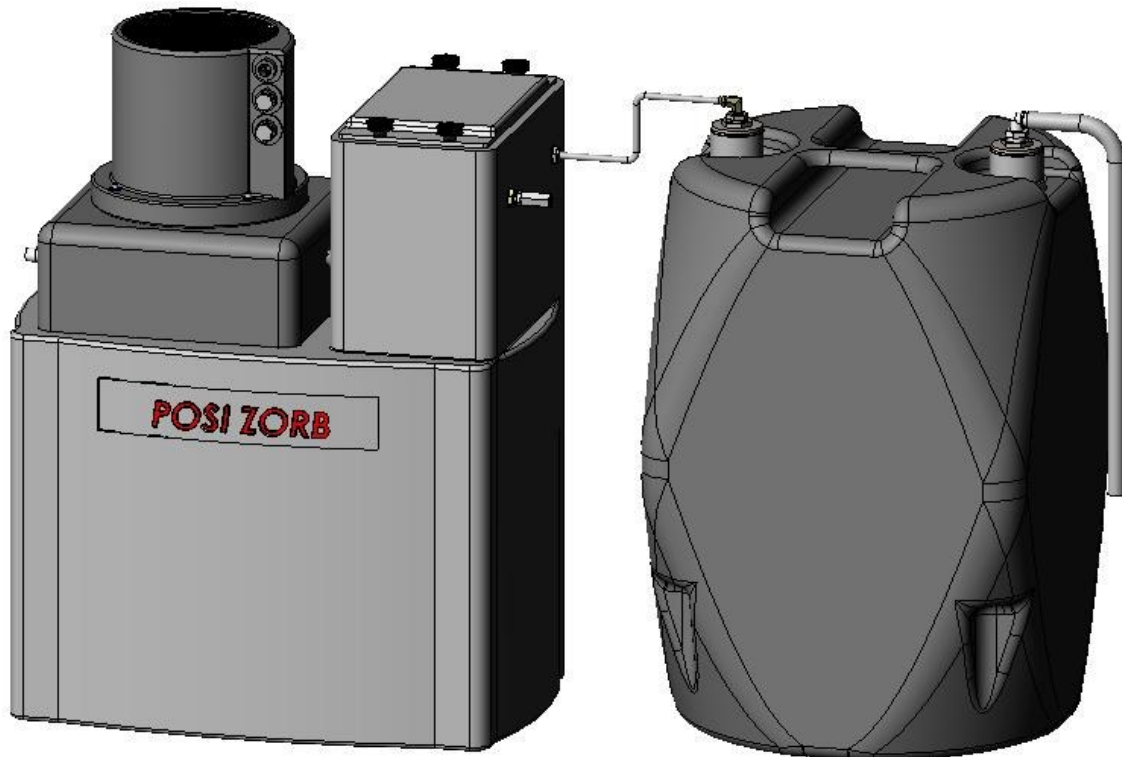

FEATURES

- Fully Automatic
- No Electricity
- Expandable System
- Extended Filter Life
- Fully Automatic
- Made in U.S.A.
- Only Two Moving Parts
- Separates Emulsified Oils
- Non-Corrosive Materials
- Non-Clogging Filter Design

AIR SYSTEM PRODUCTS, INC.

51 Beach Ave. Lancaster, NY 14086 Phone:(716)683-0435 FAX (716) 683-7128 www.airsyspro.com

"The Best in Condensate Drain Technology"

Bulletin PZ0103

The Problem

Traditional gravity type separators do very well in separating oils that have good separation characteristics. However, many compressor oils do not fully separate. These types of oils, known as emulsions, tend to foul-up the carbon filters as well as the pre-adsorption and coalescing media that are commonly installed in front of the carbon filters. Those filters have to be replaced before their capacity is fully used. This is a result of oil blinding off the pore area of the carbon where the condensate first comes in contact with the filter. The jelled oil clogs the filter, which then prevents the volume of condensate from properly flowing through the filter. This premature failure of the carbon filters most often results in the system backing up on the floor.

The Solution

The Posi Zorb was designed to effectively separate emulsified compressor condensate to levels of 15 PPM or less without premature element failure and backup spillages. To do this, the Posi Zorb uses two very unique features (patent pending). First, the Posi Zorb delivery system has a pneumatically operated pump that is used to feed the filter module. The use of pressure assures the filter will not clog. Second, the Posi Zorb Filter Module contains a proprietary blend of alumino silicate and carbon. The alumino silicate substrate is coated with a hydrophobic compound. This results in the media's ability to hold up to four times the amount of oil that standard activated carbon can hold.

Operation

The condensate enters the diffuser chamber (1) where it is depressurized. The oily condensate then enters a main reservoir (2) where gravity separation occurs. Any oil that floats to the surface is skimmed off through an adjustable oil weir (3). The condensate then moves to a separate chamber through a pick-up tube (4). As the condensate accumulates in the next chamber, a float (5) rises with the level of condensate. The float is connected to a ball valve (6) by a lever arm. The increased level of condensate causes the float to rise and open the ball valve. As the valve opens, the air-operated pump (7) is allowed to push the condensate out to the filter module (8). If the level of condensate continues to rise, the float also rises and further opens the ball valve. This results in additional condensate being pushed to the filter module. Thus, the system will self adjust to the quantity of condensate entering the system. This system assures maximum contact time for the filter module.

The Posi Zorb system only requires compressed air to operate the diaphragm pump and is only used when the level of condensate rises enough to operate the pump. The system is reliable because there are only two moving parts.

The Posi Zorb filter modules are available in three different sizes. The same delivery system is used for each filter module. Thus, an expanded air system may only require a larger filter module. Once spent, there are no messy bags to dispose of. The containers are totally self-contained and easily transported by use of a fork lift handle located on the top.

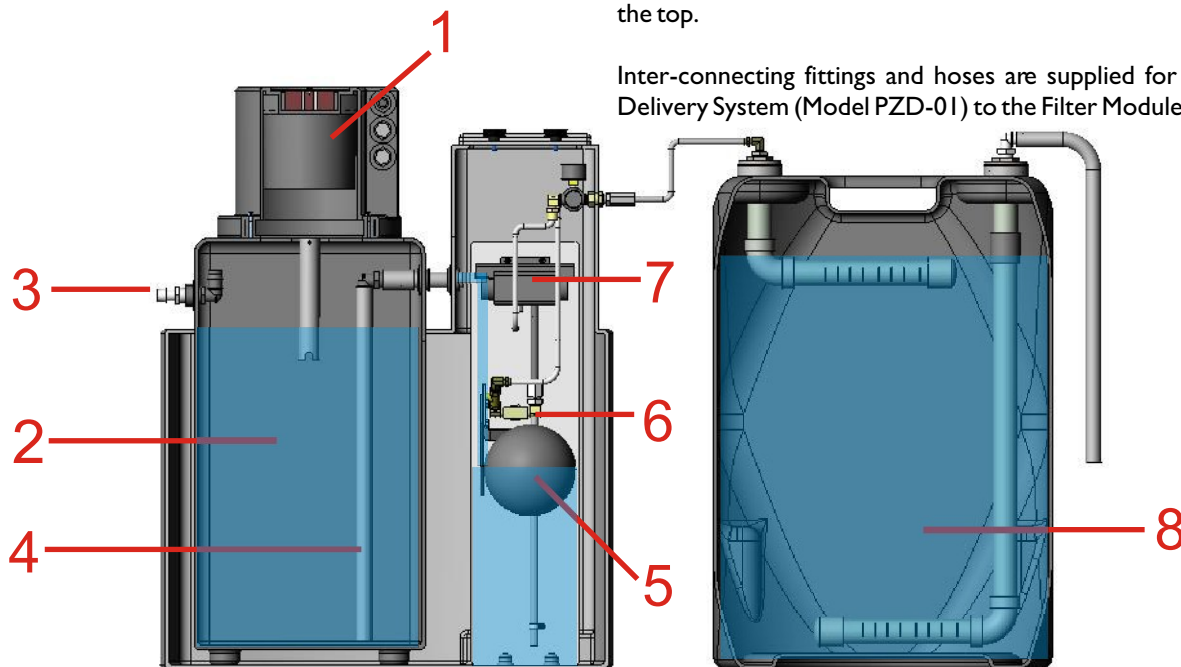

Inter-connecting fittings and hoses are supplied for connecting the Delivery System (Model PZD-01) to the Filter Modules.

Delivery System Specifications	Max. GPM	CFM @ 20psi	Height	Depth	Width	Inlet NPT	Oil Out	Container Material	Pump Material
Model: PZD-01	0.9	0.35	38"	18"	28"	(3) 1/2"	3/4"		
Filter Module Specifications	Max. Comp HP	Max. Oil Capacity	Height	Depth	Width	Inlet	Water Out	Container Material	Dry Weight
Model: PZM-15	50	5 Gal.	20"	15"	15"	3/8"	3/4"	Polyethyl	90 lbs.
Model: PZM-30	100	12 Gal.	29"	19"	19"	3/8"	2"	Polyethyl	200 lbs.
Model: PZM-55	200	24 Gal.	33"	23"	23"	3/8"	2"	Polyethyl	400 lbs.

Note: A PZM Filter Module could last 12 months in a Rotary Screw application. However, filter life may be less due to lubricant, compressor type, and maintenance.

Not recommended for silicone based lubricants. All design specifications are subject to change without notice.

AIR SYSTEM PRODUCTS, INC.

51 Beach Ave Lancaster, NY 14086 Phone:(716)683-0435 FAX (716) 683-7128 www.airsyspro.com

"The Best in Condensate Drain Technology"